

# 8200 Rotary Torque

---

## Torque transducer

- Range from 10 to 2000Nm
- Fully modular
- Various pulley types
- Sealed to IP64

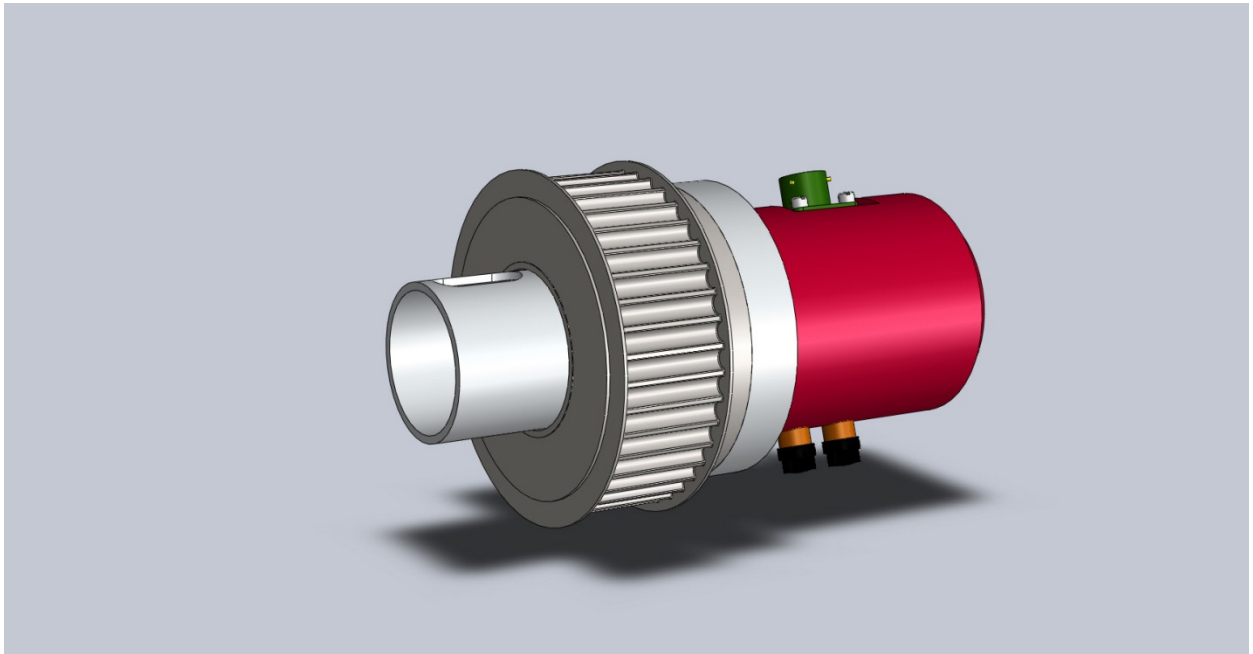

## Description

The 8200 rotary torque transducers are designed for many industrial applications for belt drives. The format of the pulley drive can be for various for differing drives. The output are via silver plated slip rings that can have as an option amplified signals.

## Specification

### ELECTRICAL

- Recommended excitation 10 Vdc.
- Maximum excitation 15 Vdc.
- Output at rated load 2.0mV/V
- Zero balance 5% of RL
- Input impedance 700ohms +/-20
- Output impedance 700ohm +/-3
- Insulation  $>10^9$ ohms
- Compensation temp range 10 to 60 C
- Safe temp range -30 to 70 C

### MECHANICAL

- Safe overload 150% of RL
- Ultimate overload 300% of RL
- Deflection  $<0.5$ mm
- Cable type 4 core screened
- Cable length 6 M
- Sealed IP68

## Accuracy

- Non linearity & hysteresis 1.0%
- Non repeatability  $<0.25$ %
- Zero return (after 30 mins). 0.05%
- Temp effect/10deg C on zero 0.02%
- Temp effect/10deg C on span 0.02%

## Wiring

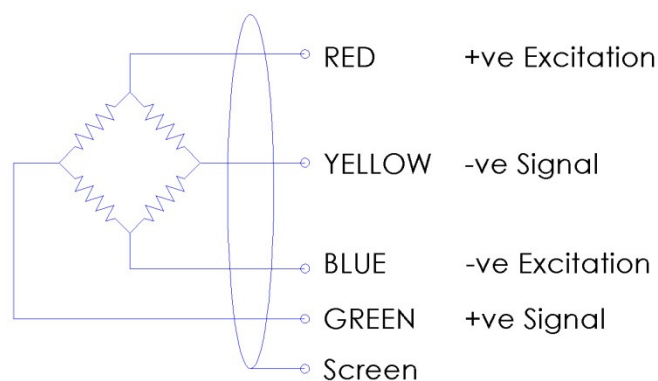

## Drawing

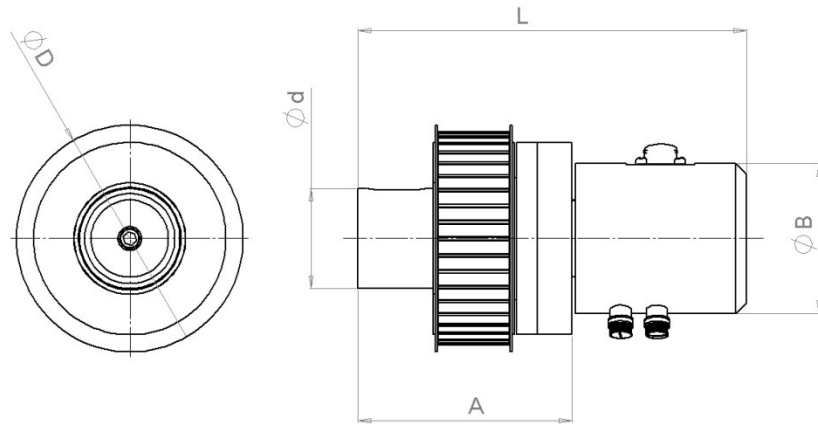

## Dimensions

RATING Nm	L mm	A mm	B mm	D mm	d mm	Remarks
10	182	100	70	106	47	
50	182	100	70	106	47	
100	182	100	70	106	47	
200						
500						
1000						
2000						

## Additional Notes

Specification may change without notice