

5550 Stub Axle Load Cell

Stub Load Cell

- Range 10 to 50kN
- Stainless steel construction.
- Rugged and easily employed
- Sealed to IP67

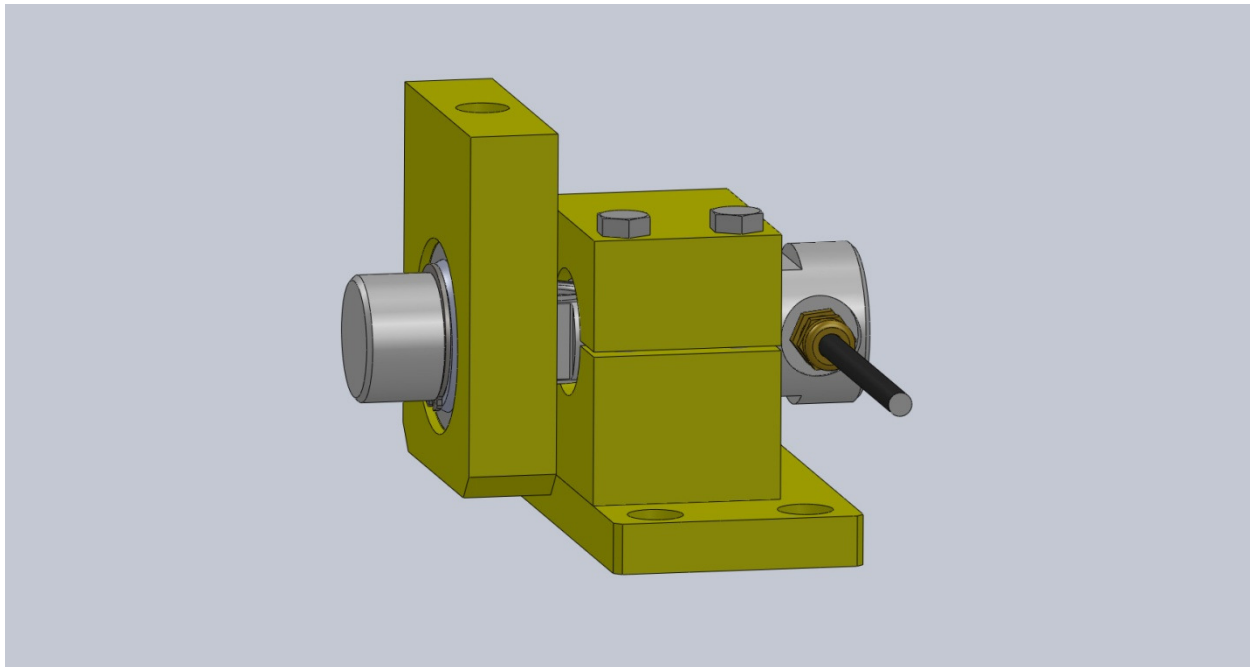

Description

The 5550 stub axle load cell has full environmental protection and is built for rugged applications. The load cell is constructed from high strength stainless steel. A complete range covers the load capacities from 10 to 50kN. Each load cell can be designed to allow transverse loading while measuring in the active plain. The load cell is built to the highest commercial standards that include temperature compensation over a wide temperature range.

Specification

ELECTRICAL

- Recommended excitation 10 Vdc.
- Maximum excitation 15 Vdc.
- Output at rated load 2.0mV/V
- Zero balance 5% of RL
- Input impedance 350ohms +/-20
- Output impedance 350ohm +/-3
- Insulation >10⁹ohms
- Compensation temp range 10 to 60 C
- Safe temp range -30 to 70 C

MECHANICAL

- Safe overload 150% of RL
- Ultimate overload 300% of RL
- Deflection <0.5mm
- Cable type 4 core screened
- Cable length 6 M
- Sealed IP67

Accuracy

- Non linearity & hysteresis 0.25%
- Non repeatability <0.05%
- Zero return (after 30 mins). 0.04%
- Temp effect/10deg C on zero 0.05%
- Temp effect/10deg C on span 0.03%

Wiring

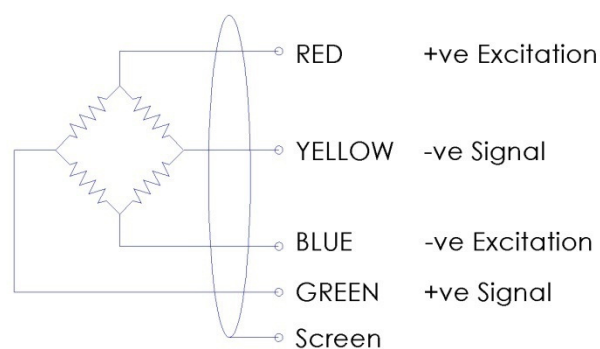

Drawing

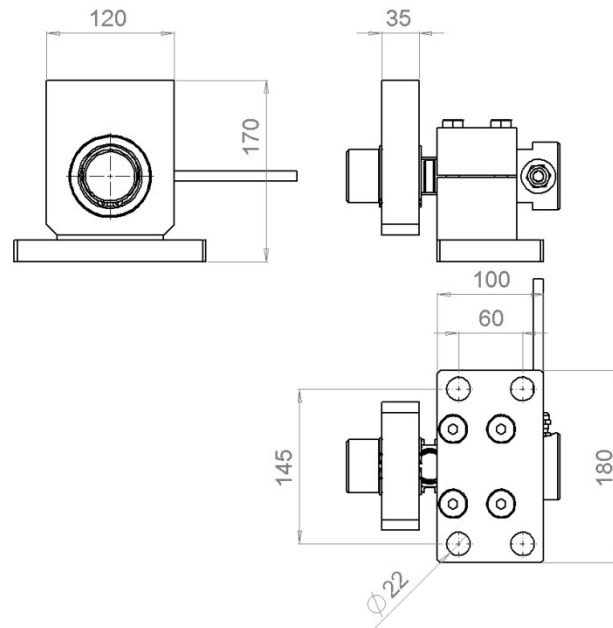

Additional Notes

Specification may change without notice