

2600 Marine Load Shackle

Shackle Pin Load Cell

- Range 50 to 500te
- Stainless steel pin.
- Rugged and easily employed
- Sealed to IP68



Description

The marine SHACKLE series of load cells are designed for measuring tensile loads using a double shear strain gauged shear pin. The range is from 50 tonne to 500tonne, with other capacities available by request. The load pin is manufactured from high strength stainless steel and fitted with stainless steel bobbin and anti-rotation plate. The load cell is used for both temporary and permanent rope tension applications, or for under hook weighing, particularly in rugged and harsh conditions. It can be also used at the dead end of a rope such as a winch or crane.

Specification

ELECTRICAL

- Recommended excitation 10 Vdc.
- Maximum excitation 15 Vdc.
- Output at rated load 2.0mV/V
- Zero balance 5% of RL
- Input impedance 700ohms +/-20
- Output impedance 700ohm +/-3
- Insulation $>10^9$ ohms
- Compensation temp range 10 to 60 C
- Safe temp range -30 to 70 C

MECHANICAL

- Safe overload 150% of RL
- Ultimate overload 300% of RL
- Deflection <0.5 mm
- Cable type 4 core screened
- Cable length 10 M
- Sealed IP68

Accuracy

- Non linearity & hysteresis 1.5%
- Non repeatability <0.25 %
- Zero return (after 30 mins). 0.05%
- Temp effect/10deg C on zero 0.02%
- Temp effect/10deg C on span 0.02%

Wiring

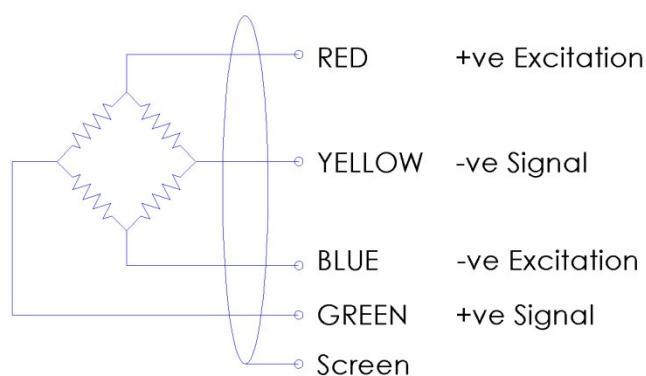

Drawing

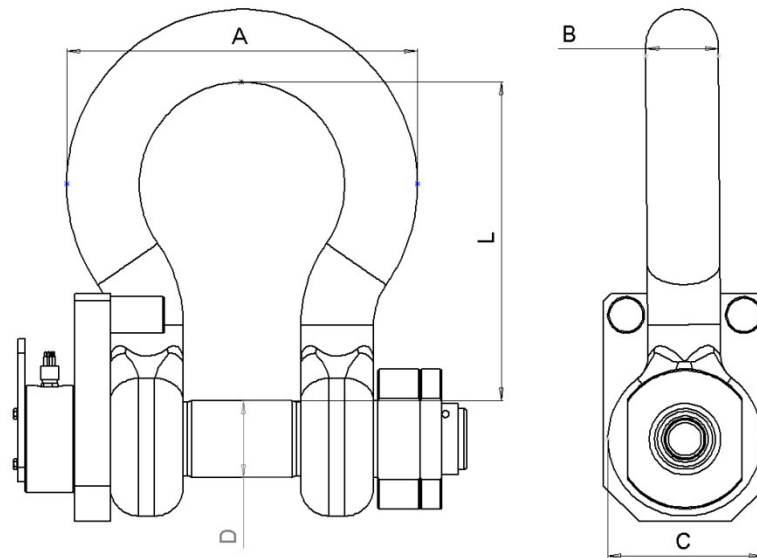

Dimensions

RATING	A	B	C	D	L	Remarks
te	mm	mm	mm	mm	mm	
50	253	53	122	57	197	
75	327	69	145	70	267	
100	365	79	165	82.5	330	
150	468	104	229	108	368	
200	533	114	267	121	397	
300	635	127	305	152	495	
400	660	152	356	178	572	
500	711	191	381	191	645	

Additional Notes

Specification may change without notice